

DISCOVER



ASSEMBLY INSTRUCTIONS

Congratulations on the purchase of your new Hilltopper Discover. This is a Class 2 electric bike with a variable speed throttle and pedal assist. Both assist systems are limited to 20 mph per class requirements.

This manual will help you finish assembling your bike.

Please feel free to take your bike to your local bike shop if you are not comfortable assembling it on your own.

LET'S GET STARTED!

UNBOXING

1. Remove all contents including:
 - Bike, Front wheel, Rack, and Small Box that contains your Pedals, Battery Charger, Quick Release Skewer and all the Tools you will need to complete the assembly
2. Remove all the plastic pieces covering the axles, they are not part of the bike.
3. Locate and remove zip-ties holding wheel, without letting it fall. Set the wheel to the side.
4. Remove other zip ties and packing materials, careful not to let the cables twist too much.
5. Remove and charge battery.

CHARGING THE BATTERY

TO CHARGE THE BATTERY PRIOR TO FIRST USE:

Remove the battery from the frame using the supplied keys.

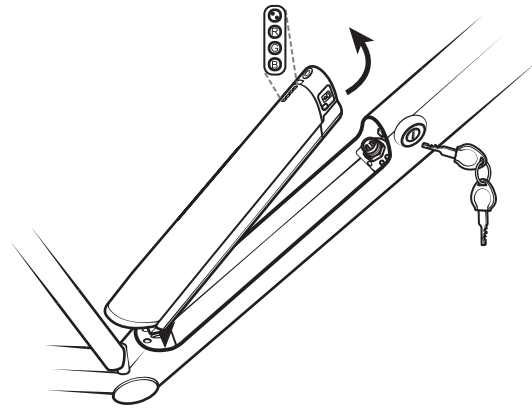

Charging Instructions:

1. Plug the charger into a wall socket.
2. Wait for the charger light to turn GREEN
3. Plug the charger into the battery.
4. The light will turn RED and stay RED while charging.
5. When the light turns GREEN your battery is charged.

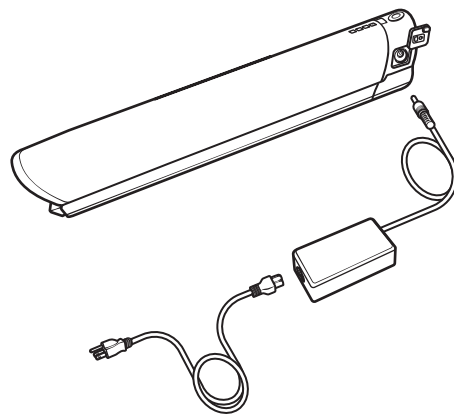

The battery button activates LEDs that indicate the charge level.

- Blue = Full
- Green = Half full
- Red = Empty



More accurate charge info is visible on the LCD screen.

FLIP TO BACK TO START BIKE ASSEMBLY

INSTALL THE BATTERY

ONCE THE BIKE IS ASSEMBLED

1. Place the battery into the downtube, aligning the bottom end first.
2. The LEDs will be facing outward and positioned towards the headtube near the lock.
3. Once everything is lined up you can snap it into place. (Make sure it is secure.)

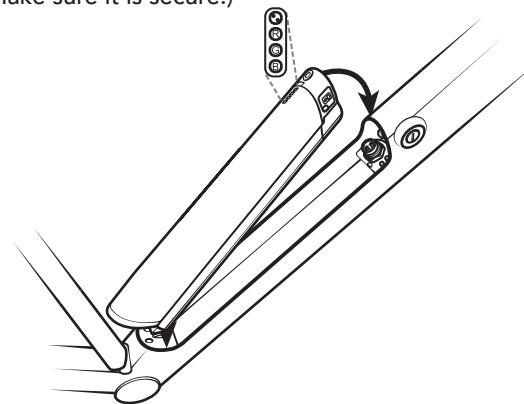

POWER AND LCD SCREEN

Press and hold the orange button on the top of the LCD screen to turn on.

The bike has 5 levels of pedal assist, with 0 being no assist.

The variable speed throttle can be used at any time, the amount of power from the throttle is dependent on the level chosen.

SHIFTING

The right hand trigger/lever shifts between the 9 gears on the rear wheel.

Pulling the lower trigger shifts to smaller/"higher"/harder gears.

Pushing the upper lever shifts to larger/"lower"/easier gears.

REMEMBER TO RIDE SAFELY, BE COURTEOUS TO OTHER RIDERS AND PEDESTRIANS, AND ENJOY DISCOVERING NEW ADVENTURES!

SAFETY GUIDELINES

Wear a properly fitted bicycle helmet.

Make sure you understand how your bike works including shifting, throttle power, and braking power.

Check your equipment. Before riding, inflate tires properly and check that your brakes work.

Remain visible by wearing bright or reflective clothing, having proper reflectors, and if possible, avoid riding at night.

Watch for and avoid road hazards.

RULES OF THE ROAD

Bicycles in many States are considered vehicles, and cyclists have the same rights and the same responsibilities to follow the rules of the road as motorists. When riding, always:

Go With the Traffic Flow. Ride on the right in the same direction as other vehicles. Go with the flow – not against it.

Obey All Traffic Laws. A bicycle is a vehicle and you're a driver. When you ride in the street, obey all traffic signs, signals, and lane markings.

Yield to Traffic When Appropriate. Almost always, drivers on a smaller road must yield (wait) for traffic on a major or larger road. If there is no stop sign or traffic signal and you are coming from a smaller roadway (out of a driveway, from a sidewalk, a bike path, etc.), you must slow down and look to see if the way is clear before proceeding. This also means yielding to pedestrians who have already entered a crosswalk.

Stay Alert at All Times. Use your eyes AND ears. Watch out for potholes, cracks, wet leaves, storm grates, railroad tracks, or anything that could make you lose control of your bike. You need your ears to hear traffic and avoid dangerous situations; don't wear a headset when you ride.

For riders over 10 Years of Age. The safest place for bicycle riding is on the street, where bicycles are expected to follow the same rules of the road as motorists and ride in the same direction.



HILLTOPPER
ELECTRIC BIKE COMPANY

sales@hilltopperbikes.com
support@hilltopperbikes.com

BIKE ASSEMBLY

INSTALL HANDLEBAR

1. Turn the stem 180° degrees so it points forward. The forks will turn with the stem.
2. Use the 4mm wrench to remove the four bolts and the front plate of the stem.
3. Set the handlebar in stem with the LCD screen and throttle on the left side of the bike.
4. Align and center the handlebar and replace the faceplate and four screws. Tighten to 6nm.

INSTALL THE SEATPOST

1. Insert the seat post into the seat tube.
2. Set to desired height and tighten using the included 5mm allen wrench. .

INSTALL THE FRONT WHEEL

1. Slide the front wheel into the fork dropouts with the disc rotor on the left side of the bike.
2. Make sure the axle is aligned straight and use the quick release skewer to secure it in place. The quick release lever goes on the left side of the bike.
3. Inflate tires to recommended (or preferred) pressure.

POSITION LCD SCREEN

1. Using the 2.5mm allen wrench, loosen the bolt and rotate the LCD screen to your desired position.
2. Make any personal adjustments to ensure you can easily view the LCD before you ride.

INSTALL THE PEDALS

On the pedals there is a small "R" for right and a small "L" for left, to let you know which side of the bike the pedal belongs to. Use the provided 15mm wrench to tighten the pedals.

1. The right pedal has regular threading. ("righty tighty lefty loosey")
2. The left side is reverse threaded so it's the opposite.

Hint: Both pedals tighten by rotating them towards the front of the bike.

INSTALL OPTIONAL RACK

Install the optional rack using the supplied hardware to the pointing points on the bike as shown in the assembly diagram

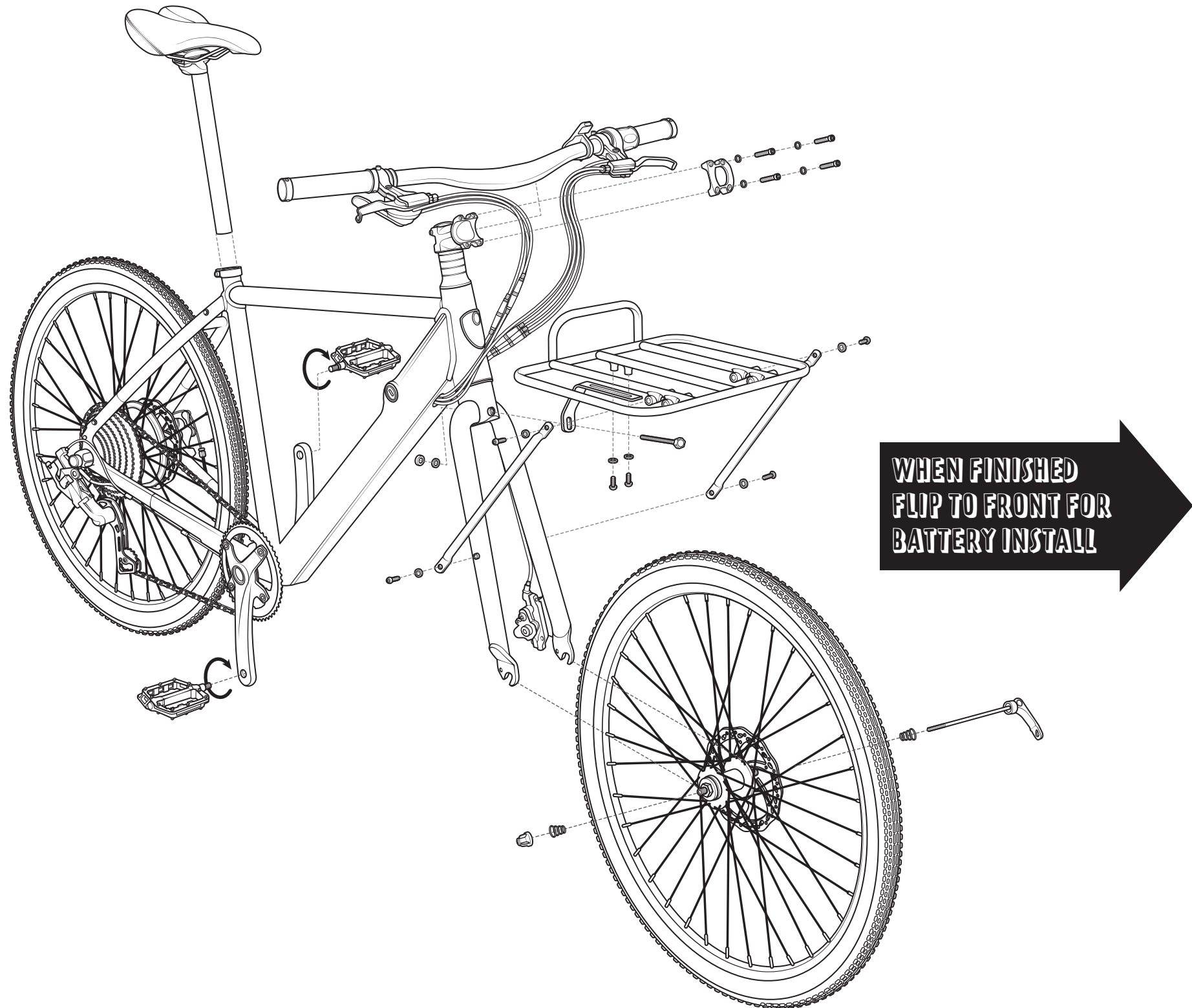

WHEN FINISHED
FLIP TO FRONT FOR
BATTERY INSTALL